

Opposite Effects of Androgen Receptor CAG Repeat Length on Increased Risk of Left-Handedness in Males and Females

Sarah E. Medland,^{1,2,3} David L. Duffy,¹ Amanda B. Spurdle,¹ Margaret J. Wright,¹
Gina M. Geffen,² Grant W. Montgomery,¹ and Nicholas G. Martin¹

Received 3 Sep. 2004—Final 1 June 2005

Prenatal exposure to testosterone has been hypothesised to effect lateralization by influencing cell death in the foetal brain. Testosterone binds to the X chromosome linked androgen receptor, which contains a polymorphic polyglutamine CAG repeat, the length of which is positively correlated with testosterone levels in males, and negatively correlated in females. To determine whether the length of the androgen receptor mediates the effects of testosterone on laterality, we examined the association between the number of CAG repeats in the androgen receptor gene and handedness for writing. Association was tested by adding regression terms for the length of the androgen receptor alleles to a multi-factorial-threshold model of liability to left-handedness. In females we found the risk of left-handedness was greater in those with a greater number of repeats ($p=0.04$), this finding was replicated in a second independent sample of female twins ($p=0.014$). The length of the androgen receptor explained 6% of the total variance and 24% of the genetic variance in females. In males the risk of left-handedness was greater in those with fewer repeats ($p=0.02$), with variation in receptor length explaining 10% of the total variance and 24% of the genetic variance. Thus, consistent with Witelson's theory of testosterone action, in all three samples the likelihood of left handedness increased in those individuals with variants of the androgen receptor associated with lower testosterone levels.

In western populations approximately ten percent of the population use their left hand for writing and other unimanual activities (although this estimate varies with the age of participants (McManus, 2002; OMIM 139900). Traditionally handedness has been studied because of the relationship between handedness and language lateralization. While approximately 95% of right handers show left-hemisphere language dominance, left-hemisphere language dom-

inance is seen in around 75% of neurologically normal left-handers (Pujol *et al.*, 1999). More recently, research has also explored links between hand preference and a wide range of traits including Schizophrenia (Klar, 1999; Satz and Green, 1999; Shaw *et al.*, 2001), Language function (Bishop, 2001; Natsopoulos *et al.*, 2002) and Autism (Cornish and McManus, 1996; Hauck and Dewey, 2001). While ultrasound studies have revealed evidence of laterality before birth (Hepper *et al.*, 1998, 1990), genetic (Annett, 1985; McManus, 1985), pathogenic (Satz *et al.*, 1985) and androgenic theories have been proposed to explain the origins of behavioural lateralization.

The Androgen theories which are the focus of the current paper predict that pre-natal exposure to testosterone influences cell death in the foetal brain,

¹ Queensland Institute of Medical Research, PO Royal Brisbane Hospital, Australia.

² Cognitive Psychophysiology Laboratory, University of Queensland, Australia.

³ To whom correspondence should be addressed at Queensland Institute of Medical Research, PO Royal Brisbane Hospital, Brisbane 4029, Australia. Tel: +61-7-3362-0286. Fax: +61-7-3362-0101. e-mail: sarahMe@qimr.edu.au

resulting in decreased functional lateralization, affecting both cerebral and behavioural lateralization. Geschwind-Behan-Galburda (Geschwind & Behan, 1982; Geschwind & Galburda 1987) have proposed that exposure to *high* levels of testosterone in utero results in decreased lateralization and an increased likelihood of left-handedness. Conversely, Witelson and Nowakowski (1991) proposed that *low* testosterone levels are associated with increased left handedness. The results of studies examining the relationship between lateralization and testosterone levels in adults have been mixed, some finding higher testosterone in left handers (Tan, 1990a, b) and others have found lower testosterone (Gadea *et al.*, 2003; Moffat and Hampson, 1996). In the only study to directly examine this relationship, Grimshaw *et al.* (1995), found that females with lower levels of testosterone in the second trimester amniotic fluid were more likely to be left handed at age 10, but no relationship was observed in males. While previous research has focused on exposure to testosterone from external sources (i.e. the potential exposure of a female foetus to the testosterone of a male co-twin) and circulating testosterone levels, the present study concentrates on the pathway through which testosterone acts.

In the brain, testosterone acts either through the activation of the X chromosome linked androgen receptor (OMIM 313700, also known as the Dihydrotestosterone receptor, located at Xq11-12) or, after aromatisation to estradiol, through the estrogen receptor (McAbee and DonCarlos, 1999). The focus of the current paper is the polymorphic CAG repeat present in the first exon of the Androgen receptor, which encodes a polyglutamine tract of variable length. The transcriptional activity of the androgen receptor is negatively related to the length of a polymorphic polyglutamine CAG repeat (Chamberlain *et al.*, 1994; Choong *et al.*, 1996). Chamberlain *et al.* (1994) examined the transcriptional transactivation abilities of human androgen receptors with 25, 35, 49 and 77 repeats and found a high negative correlation (-0.998) between repeat number and receptor activity. Expansion to 40–62 repeats; the range seen in X-linked spinal and bulbar muscular atrophy (La Spada *et al.*, 1991), was associated with a loss of function of approximately 10–30% when compared to the wide type receptor, leading to the conclusion that there may be a minimum level of androgen receptor activity required within motor neurons.

Indirect evidence also suggests that variation within the normal range may have functional significance for a variety of traits (Yeap *et al.*, 2004).

CAG_n and testosterone levels are positively correlated in males (Krithivas *et al.*, 1999), and negatively correlated in normal females, suggesting that the major influence of the androgen receptor on androgen production differs between males and females (Westberg *et al.*, 2001). A negative, but non-significant trend was also reported in females by Haiman *et al.*, (2002) Shorter repeats within the normal range have been implicated in prostate cancer risk and age of onset (Giovannucci *et al.*, 1997; Hardy *et al.*, 1996; Irvine *et al.*, 1995). Longer repeat sequences are associated with increased risk of impaired spermatogenesis in men (Tut *et al.*, 1997) and polycystic ovary syndrome in women (Hickey *et al.*, 2002). Recently, elongated repeat tracts have been found to alter axonal function (Piccioni *et al.*, 2002), and androgen receptor mediated effects of testosterone have been shown to exhibit a neuroprotective effect in human foetal brain tissue (Hammond *et al.*, 2001). The results of these studies suggest that variation in the length of the androgen receptor gene can influence neural development.

Two previous studies have examined linkage on the X chromosome for relative hand-skill as measured by a peg-moving task. In 1998, Laval *et al.*, with a sample of 180 pairs of brothers who were left-handed for writing found a maximum LOD score of 2.80 which was centred on DXS990 (located at Xq13.3, 92.8 Mb) lying between DXS453 and COL4A5. More recently, Francks *et al.* (2002), with a sample of 195 sib-pairs found the strongest evidence of linkage on the X-chromosome lay between DXS993 (41 Mb) and DXS991 (54 Mb) on Xp11. The empirical *p* value of this peak was only 0.07. However, reanalysis of this data using only the 79 brother–brother pairs (an analysis which they consider to be more comparable to Laval *et al.*) produced a *p* value of 0.012 (LOD score of 1.09). As shown in Figure 1, the androgen receptor at Xq11-12 (67 Mb) lies between these two linkage regions.

We postulated that any effects of testosterone on behavioural laterality might be mediated by the activity of the receptor molecules through which it acts, namely the androgen receptor. Given that the transcriptional activity of androgen receptor varies with the length of the repeat sequence we tested the association between the number of CAG repeats in the androgen receptor gene and handedness. The association was examined in two independent samples of female twins and one sample of male twins, by adding regression terms for the length of the androgen receptor alleles to a multi-factorial-threshold

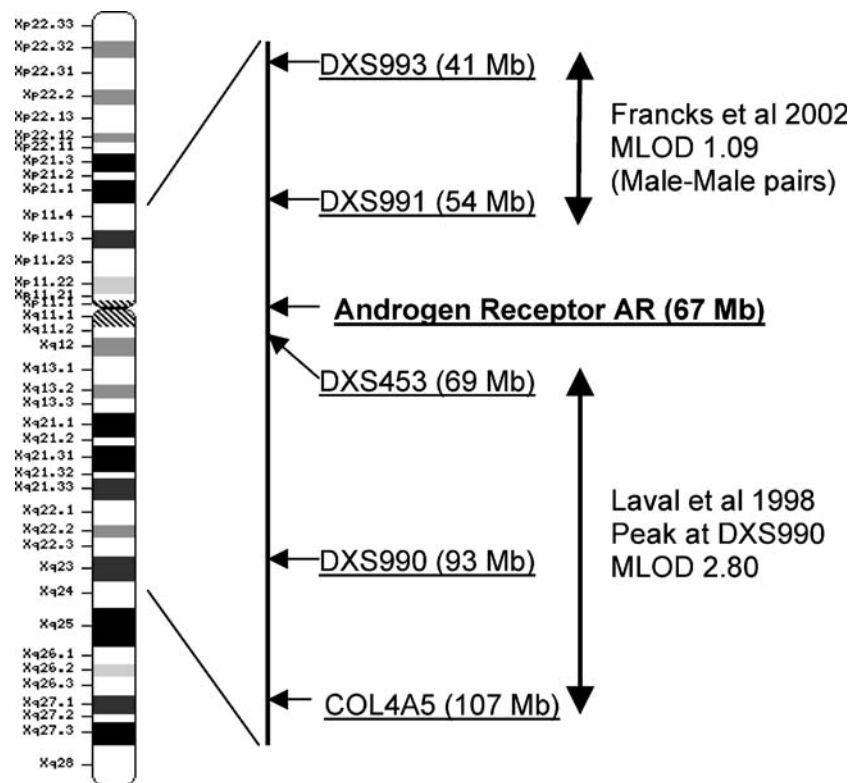

Fig. 1. Location of the androgen receptor in relation to the linkage regions identified by Francks *et al.* (2002) and Laval *et al.* (1998). Map distances from NCBI Build 35.1, ideogram from Map View NCBI (date of information: 22/04/05).

model of liability to left-handedness (this model is described in the Methods). As converse relationships are observed between CAGn and testosterone levels in males and females the data of males and females were analysed separately. In females we analysed the mean length of the two alleles, as well as the length of the longer and shorter alleles separately. We found that for two independent samples of females the risk of left handedness increased with allele length, while the opposite was observed in males, paralleling the opposing relationships observed between CAGn and testosterone in males and females.

MATERIALS AND METHODS

Participants

The first study was based on a sub-sample of adult female MZ twins (and their co-twins) who had previously been genotyped for the androgen receptor as controls in an ovarian cancer study (Spurdle *et al.*, 2000). Handedness data were available for some of these participants due to their participation in previous studies; the remaining participants were sent a

questionnaire asking about their handedness. Because of the age of this sample (year of birth ranged from 1917 to 1963: M 1943, sd 13.1) those who reported a change in handedness were excluded from further analysis. Thus, the first sample was composed of 110 complete pairs, 47 single twins. Handedness was defined as the hand used for writing. Participants were asked: *Which hand would you usually use to write a letter legibly: left/either/right?* Participants who answered either were treated as left-handers. Of the 267 participants 19 were left handed; for the complete twin pairs the numbers of LL, LR and RR pairs were 0, 16 and 96, respectively. The number of CAG repeats in this sample ranged from 9 to 30 (mean 21.96, standard deviation 3.01).

The second sample comprised 43 MZ and 69 complete and 18 incomplete DZ female twin pairs, and 38 MZ and 73 complete and 17 incomplete DZ male twin pairs who had participated in the Brisbane Adolescent Twin Study (the protocol of this study is described extensively elsewhere; Wright *et al.*, 2001). Handedness was measured as described previously. Of the female participants 28 were left handed; the

numbers of LL, LR and RR pairs were 3, 5, 35 for MZ twins and 1, 13, 55 for DZ twins, respectively. Of the male participants 29 were left handed; the numbers of LL, LR and RR pairs were 1, 5, 32 for MZ twins and 1, 16, 56 for DZ twins, respectively. All twins were same-sex pairs, born 1978–1988 (M 1983, sd 2.4). Twins from opposite sex-pairs were not included in these analyses as it has been suggested that females from opposite twin pairs may be exposed to the testosterone of the male co-twins (although Elkadi *et al.*, 1999 found no differences in the handedness of those in same – as compared to opposite-sex pairs). Participants in the second sample were genotyped by the Australian Genome Research Facility (Ewen *et al.*, 2000) as part of an ongoing linkage study for a range of cognitive and physiological traits (see Zhu *et al.*, 2004, for a description of the protocol). The number of repeats ranged from 12 to 29 (Male M 21.04, sd 2.69; Female M 21.47, sd 2.84). Of the MZ pairs included in these analyses only one twin from each pair was genotyped and it was assumed that the co-twin would show an identical genotype.

Statistical Analyses

For this study we assume a Multi-Factorial Threshold (MFT) model which posits a continuous normally distributed liability for laterality on which thresholds are imposed which define the prevalence of left-handedness. The model assumes that the joint distribution of liabilities for a pair of twins is bivariate normal, and the correlation between liabilities can be estimated as a random effect, thus correcting for the non-independence of observations while estimating the fixed effects on the thresholds. Allele length (CAG_n) was included as a fixed effect in a threshold model, as part of the Maximum Likelihood Estimation procedure implemented in Mx (version 1.54), which we use for these analyses (Neale *et al.*, 2002). By using Mx for these analyses the data is modelled at a family level rather than an individual level. As such the twin data is not analysed as if it were derived from two independent individuals, instead the relationship between the siblings is explicitly modelled. In the case of the MZ twins inclusion of both twins (13% of whom are discordant for handedness) will act to reduce the rates of false positives.

The significance of the association of handedness with the Androgen receptor was assessed by dropping the regression term from the model and comparing the resulting difference in $-2LL$ to the critical value of

the χ^2 distribution for one degree of freedom. This method has previously been used to identify associations between D9S942 marker CA_n repeat number and mole count (Zhu *et al.*, 1999).

RESULTS

Prevalence of Left-Handedness

A series of preliminary analyses were conducted to determine whether there were any differences in the prevalence of left-handedness between first and second-born twins, MZ and DZ twins (as hypothesised by the theory of mirror imaging; Newman, 1928). There were no effects of birth order on the prevalence of left-handedness in the first sample ($\chi^2_1 = 0.63$, *ns*) or the second samples ($\chi^2_{2\text{female}} = 0.71$, $\chi^2_{2\text{male}} = 5.08$, *ns*). Similarly, there were no differences in prevalence between MZ and DZ twins ($\chi^2_{1\text{female}} = 0.26$, $\chi^2_{1\text{male}} = 0.29$, *ns*) suggesting that mirror imaging (if present in the data set) is not having a significant effect in this sample. The overall prevalence of left-handedness in these samples, (7.1, 11.5 and 12.1%, respectively) are similar to those reported in singletons (Annett, 2002; McManus, 2002). Fitting an age correction to the data did not improve the fit of the model in either the first ($\chi^2_1 = 2.12$, *ns*) or second sample ($\chi^2_{1\text{female}} = 0.01$, $\chi^2_{1\text{male}} = 0.17$, *ns*) suggesting that there were no significant age effects within the samples. The difference in prevalence between the first and second samples reflects the older age of the participants in the first sample some of whom would have experienced active coercion against left-handedness while learning to write (McManus, 2002; Medland *et al.*, 2003).

Association Analyses

Female Data

First Sample

As shown in Table I, addition of a regression term for the length of the longer allele significantly improved the fit of the model, with the probability of left-handedness increasing with the number of CAG repeats in the longer allele ($\beta = 0.064$, $p = 0.04$). The positive sign of this coefficient indicates that the threshold is being shifted towards the right thus increasing the risk of left handedness. However, regression for the length of the shorter allele did not alter the fit of the model and the regression for the mean allele length, although in the same direction ($\beta = 0.059$) was not significant. While the distribu-

Table 1. Results of Fitting Regression Models for the Length of the Androgen Receptor to the Multifactorial Threshold Model of Liability for Left-handedness

Regression model	Second sample females		Males	
	First sample females			
Mean allele length ($\Delta X \hat{1}$)	1.82	5.99 ^a	5.20 ^a	
β (CI)	0.059 (-0.034-0.078)	0.086 (0.024-0.097)	-0.059 (-0.070- -0.111)	
Length of shorter allele ($\Delta X \hat{1}$)	0.00	3.27		
β (CI)	0.001 (-0.066-0.079)	0.093 (-0.008-0.104)		
Length of longer allele ($\Delta X \hat{2}$)	4.22 ^a	6.79 ^b		
β (CI)	0.064 (0.003-0.072)	0.081 (0.026-0.090)		
Length of both longer and shorter alleles ($\Delta X \hat{2}$)	5.37	6.79 ^a		
	Short -0.045 (-0.132-0.038)	Short -0.001 (-0.010-0.098)		
β (CI)	Long 0.101 (0.01-0.166)	Long 0.082 (-0.004-0.164)		

Regression models are compared with a model in which the thresholds are constrained to be equal. regression betas are given in italics (95% Confidence Intervals are given in parentheses). ^a $p < 0.05$, ^b $p < 0.01$.

tions of CAGn by handedness appear similar (Figure 2), (means and standard deviations of CAGn in left- 22.58 (3.51), and right-handers 21.92 (2.96)), the skewed distribution of left-handed females towards longer repeats becomes apparent when considering the longer of the two alleles (Means (sd): left- 24.84 (2.31), and right-handers 23.54 (2.62)). The point biserial correlations between handedness (coded left = 0, right = 1) and repeat length were: -0.002, -0.128* and -0.080 for shorter, longer, mean repeat length respectively (* $p < 0.05$).

Second Sample

In the second sample, the likelihood of left-handedness increased with the mean length of the two alleles ($p = 0.014$). As seen in the first study, regression for the length of the longer of the two alleles resulted in a highly significant improvement in fit ($p = 0.009$) while regression for the length of the shorter allele did not significantly alter the fit of the model ($p = 0.071$). An examination of the model where separate regression terms have been estimated for the lengths of the two alleles reveals a similar pattern of results. In this model the relative magnitude of the regression betas ($\beta_{short} = -0.001$, $\beta_{long} = 0.082$) suggests that as in the first study the significant association between XAR and hand preference is being driven by the length of the longer of the two alleles. As seen in Figure 3 the negative skewing of the allele frequency distribution in left handers is accentuated in the distribution of the longer allele. The mean allele length of left-handers was approximately one repeat longer than that seen in the right-handers (means and standard deviations of CAGn in left- 21.82 (1.86), and right-handers 20.53 (2.06)). This difference increased to approximately 1.5 repeats when considering the longer of the two alleles (Means (sd): left- 23.6 (2.24), and right-handers 22.01 (2.58)). Thus, as was seen in the first study data the likelihood of left handedness increases with the number of CAG repeats in the longer allele. The point biserial correlations between handedness (coded left = 0, right = 1) and repeat length were: -0.142*, -0.198* and -0.199* for the shorter, longer, mean repeat length respectively (* $p < 0.05$).

Estimating the Effect Size

To estimate the magnitude of the regression effects we used structural equation modelling decomposing the phenotypic variance into that due to additive genetic (A), common environmental (C) and unique or non-shared environmental (E) influences.

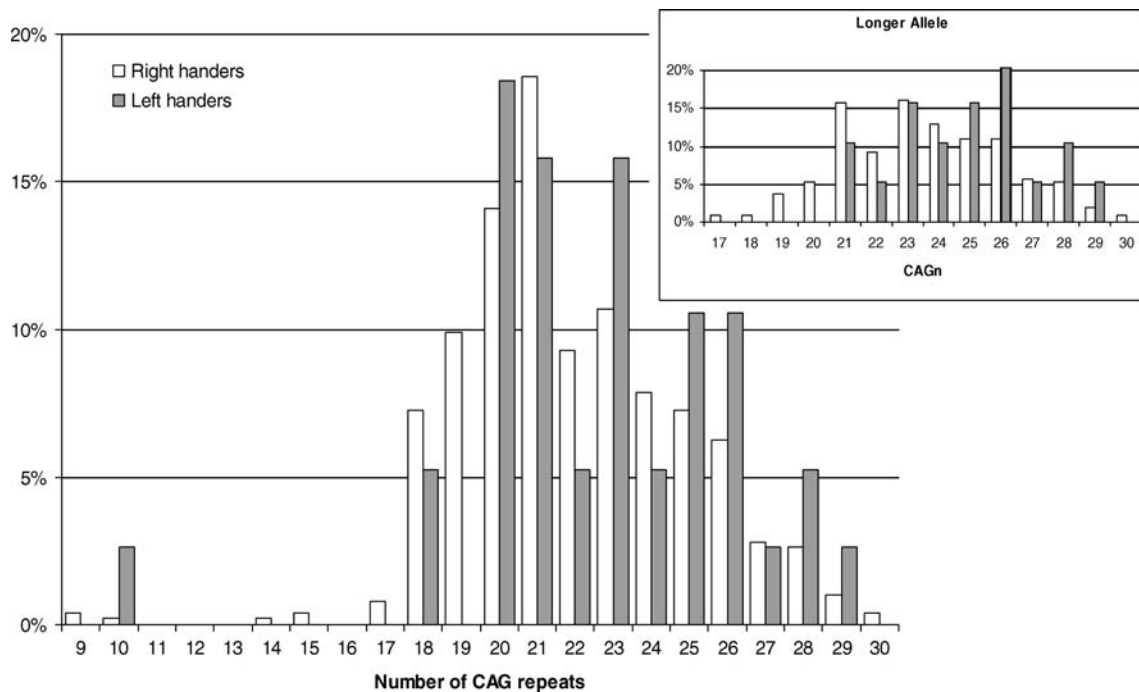

Fig. 2. Androgen receptor exon 1 CAGn allele frequency distribution in left- and right-handers from the first study (both the longer and shorter alleles are shown). The distribution of the longer allele only is shown in the insert.

By estimating the relative magnitude of A, C and E with and without regression terms we were able to estimate the proportion of genetic variance due to the XAR polymorphism ($\Delta\sigma_A^2$). The data from both studies were included as separate groups in these analyses, the prevalences of left-handedness and the magnitude of the regression beta were allowed to differ between the samples. Adding a regression term for the mean allele length reduced the heritability estimate for liability to left handedness from 0.25 to 0.19, suggesting that the polymorphism accounts for around 6% of total variance in liability to left-handedness and around 24% of genetic variance in this sample of females.

Male Data

Association Analyses

Adding a regression term for the length of the single XAR allele to the multi-factorial model of left-handedness improved the fit of the model ($p = 0.022$). However, contrary to the pattern of results observed in the two samples of females in the male data the risk of left-handedness decreased as the number of CAG repeats increased ($\beta = -0.059$). The distribution of alleles for left- and right-handers is shown in Figure 4

(Means (sd): left- 19.59 (3.19), and right-handers 20.83 (2.78)). The point biserial correlation between handedness (coded left=0, right=1) and repeat length was: 0.138 ($p < 0.05$).

Effect Size

As described above we fitted univariate genetic models to the data in order to estimate the proportion of variance being accounted for by this polymorphism. Adding a regression term for the allele length reduced the heritability estimate from 0.42 to 0.32, indicating that the polymorphism accounts for around 10% of total variance in liability to left-handedness in males and around 24% of genetic variance in this sample of males.

DISCUSSION

Our results show that the repeat expansion of the androgen receptor gene influences the probability of left-handedness in females, such that left-handedness was more common among those with a greater number of CAG repeats. In the first sample this relationship was only significant when considering the longer of the two alleles. In the second sample this relationship was significant for the mean allele length

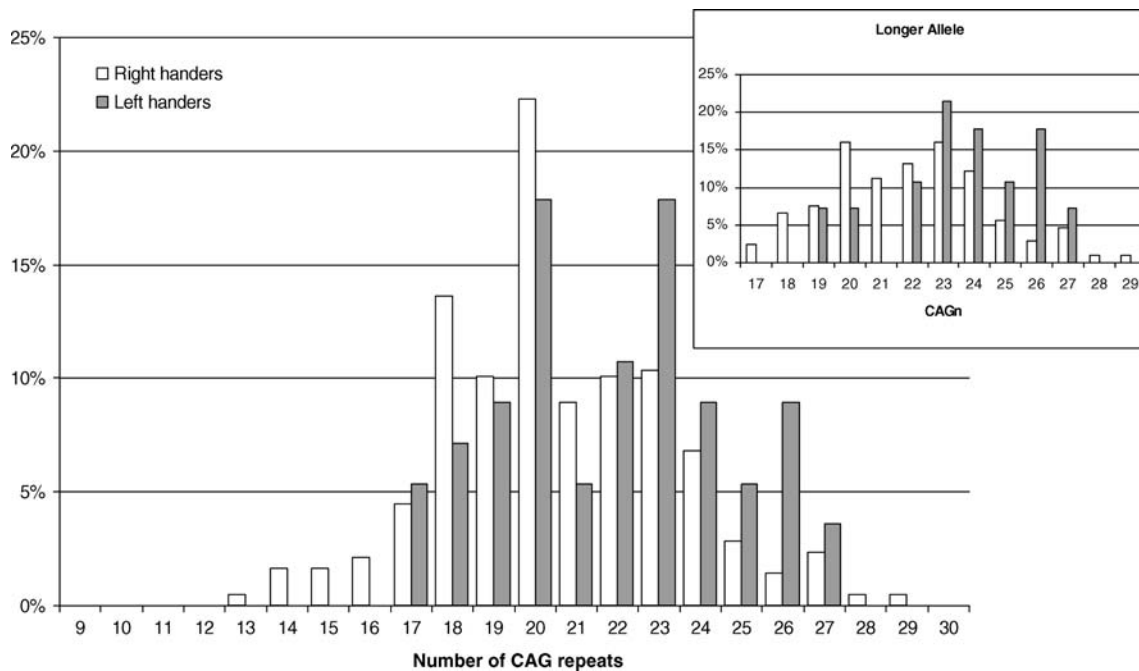

Fig. 3. Androgen receptor exon 1 CAGn allele frequency distribution in left- and right-handers for the females of the second study. The distribution of the longer allele is shown in the insert.

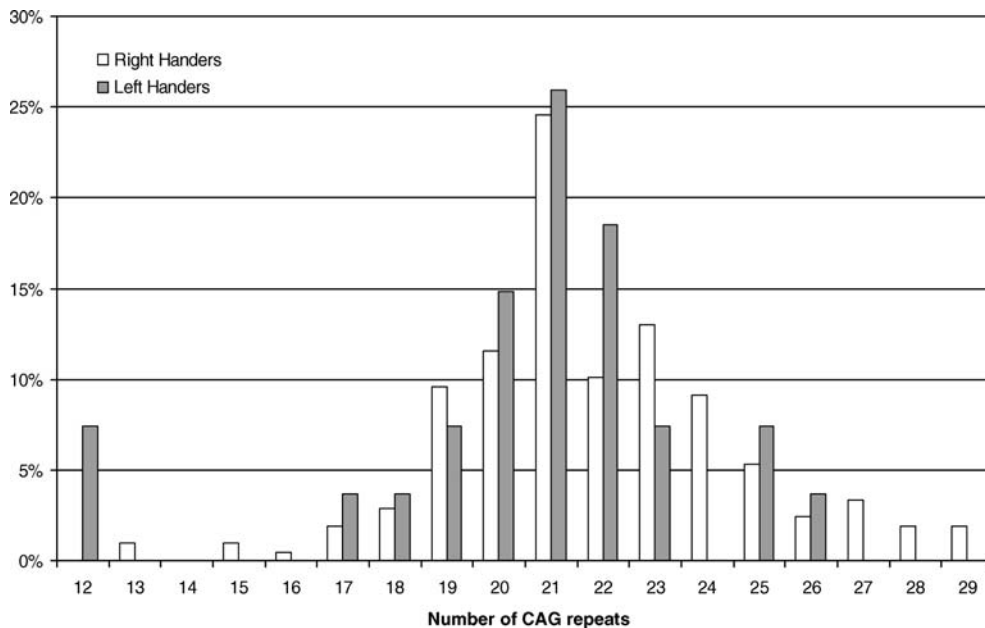

Fig. 4. Androgen receptor exon 1 CAGn allele frequency distribution in left- and right-handed males.

and when both alleles were considered at the same time. However, as seen in the first sample this effect was driven by the longer of the two alleles.

One possible interpretation of these findings is that the shorter of the two alleles may be preferentially inactivated (as has been observed in polycystic

ovary syndrome Hickey *et al.*, 2002) and that the effect may be strongest when the longer allele is on the active X in the majority of cells within specific regions of the brain such as the corpus callosum. Alternatively, if we assume random X inactivation expansion may affect lateralization only after it passes a certain threshold (i.e. after CAG₂₂) resulting in dominance of the longer allele. Given that fewer CAG repeats are associated with higher testosterone levels in females (Westberg *et al.*, 2001) our results support Witelson's hypothesis, and the results of Grimshaw *et al.* (1995). These results are also consistent with studies reporting expansion of the androgen receptor as a risk factor in breast cancer (for review see Lillie *et al.*, 2003), which has been found to occur more commonly in left- than right handers (Anbazhagan and Gusterson, 1992; Kramer *et al.*, 1985a, b; London, 1992; London and Albrecht, 1991; McManus, 1992; Sandson *et al.*, 1992; Titus-Ernstoff *et al.*, 2000).

In males, we found the inverse relationship between CAG_n and handedness such that the likelihood of left-handedness decreased as the number of repeats increased. This apparent paradox is consistent with the relationship that has been reported between receptor length and testosterone levels. In males, variants of the androgen receptor gene with a smaller number of CAG repeats (i.e. those coding for a more active receptor) are associated with lower levels of androgens (Krithivas *et al.*, 1999), and a increased risk of left-handedness.

Taken together, our findings suggest that the probability of left handedness in both males and females is associated with the length of the androgen receptor, such that the risk of left handedness is increased in those individuals with variants of the androgen receptor associated with lower testosterone levels. Although statistically significant, differences in the repeat length between left- and right-handers were fairly modest. However, Chamberlain *et al.* have estimated that the decline in transactivation function in individuals with X-linked spinal and bulbar muscular atrophy may be as low as 10–30% (Chamberlain *et al.*, 1994), suggesting that clinically, and in our case phenotypically significant outcomes may be associated with small decreases in protein function.

These data do not answer the question as to whether the relationship we observe between the androgen receptor and handedness is mediated by testosterone exposure, or whether there is a direct effect of the androgen receptor gene *per se*. Unfortunately, information regarding prenatal

testosterone levels, CAG_n and handedness would be required to determine the proportion of variance in handedness uniquely attributable to the variation in the length of the androgen receptor polymorphism.

In conclusion, we have shown an association between handedness and the androgen receptor polymorphism in two independent samples of females and one sample of males. While numerous studies have explored the relationship between testosterone and handedness, the present study is the first to examine the influences of the androgen receptor gene on handedness. Consistent with Witelson's theory of testosterone action, in all three samples the likelihood of left handedness increased in those individuals with variants of the androgen receptor associated with lower testosterone levels.

ACKNOWLEDGMENTS

The authors thank the twins and their families for their participation, Peter Visscher, Manuel Ferreira, David Evans, Huntington Willard and two anonymous reviewers for comments on an earlier draft of this manuscript, Ann Eldridge, Kim Eldridge, Marlene Grace and Alison MacKenzie for their assistance with data collection. This work was carried out with the support of the Australian Research Council (Grant Numbers: A79600334, A79906588, A79801419) and the Human Frontier Science Program (Grant Number: RG0154/1998-B).

ELECTRONIC DATABASE INFORMATION

The URL for data presented herein is as follows: Online Mendelian Inheritance in Man (OMIM), <http://www.ncbi.nlm.nih.gov/Omim/> for Handedness (MIM 139900) and Androgen Receptor (MIM 313700).

REFERENCES

- Anbazhagan, R., and Gusterson, B. A. (1992). Reversed cerebral asymmetry and breast cancer. *Lancet* **339**:1056.
- Annett, M. (1985). *Left, Right, Hand and Brain: The Right Shift Theory*. London: Lawrence Erlbaum Associates.
- Annett, M. (2002). *Handedness and Brain Asymmetry: The Right Shift Theory*. Hove: Psychology Press.
- Bishop, D. (2001). Individual differences in handedness and specific speech and language impairment: evidence against a genetic link. *Behav. Genet.* **31**:339–351.

- Chamberlain, N. L., Driver, E. D., and Miesfeld, R. L. (1994). The length and location of CAG trinucleotide repeats in the androgen receptor N-terminal domain affect transactivation function. *Nucleic Acids Res.* **22**:3181–3186.
- Choong, C., Kempainen, J., Zhou, Z., and Wilson, E. (1996). Reduced androgen receptor gene expression with first exon CAG repeat expansion. *Mol. Endocrinol.* **10**:1527–1535.
- Cornish, K., and McManus, I. (1996). Hand preference and hand skill in children with autism. *J. Autism Dev. Disord.* **26**:597–609.
- Elkadi, S., Nicholls, M., and Clode, D. (1999). Handedness in opposite and same-sex dizygotic twins: testing the testosterone hypothesis. *Neuroreport: An Int. J. Rapid Commun. Res. Neurosci.* **10**:333–336.
- Ewen, K. R., Bahlo, S., Treloar, S. A., Levinson, D. F., Mowry, B., Barlow, J. W., and Foote, S. J. (2000). Identification and analysis of error types in high-throughput genotyping. *Am. J. Human Genet.* **67**:727–736.
- Francks, C., Fisher, S., MacPhie, L., Richardson, A., Marlow, A., Stein, J., and Monaco, A. (2002). A genomewide linkage screen for relative hand skill in sibling pairs. *Am. J. Human Genet.* **70**:800–805.
- Gadea, M., Gomez, C., Gonzalez-Bono, E., Salvador, A., and Espert, R. (2003). Salivary testosterone is related to both handedness and degree of linguistic lateralization in normal women. *Psychoneuroendocrinology* **28**:274–287.
- Geschwind N. and Behan, P. (1982). Left-handedness: Association with immune disease, migraine, and development learning disorder. *Proc. Natl. Acad. Sci. USA* **79**: 5097–5100.
- Geschwind, N., and Galaburda, A. M. (1987). *Cerebral Lateralization*. Cambridge, MA: MIT Press.
- Giovannucci, E., Stampfer, M. J., Krithivas, K., Brown, M., Brufsky, A., Talcott, J., Hennekens, C. H., and Kantoff, P. W. (1997). The CAG repeat within the androgen receptor gene and its relationship to prostate cancer. *Proc. Natl. Acad. Sci. USA* **94**:3320–3323.
- Grimshaw, G., Bryden, M. P., and Finegan, J. K. (1995). Relations between prenatal testosterone and cerebral lateralization in children. *Neuropsychology* **9**:68–79.
- Haiman, C. A., Brown, M., Hankinson, S. E., Spiegelman, D., Col-ditz, G. A., Willett, W. C., Kantoff, P. W., and Hunter, D. J. (2002). The androgen receptor CAG repeat polymorphism and risk of breast cancer in the Nurses' Health Study. *Cancer Res* **62**:1045–1049.
- Hammond, J., Le, Q., Goodyer, C., Gelfand, M., Trifiro, M., and LeBlanc, A. (2001). Testosterone-mediated neuroprotection through the androgen receptor in human primary neurons. *J. Neurochem.* **77**:1319–1326.
- Hardy, D. O., Scher, H. I., Bogenreider, T., Sabbatini, P., Zhang, Z.-F., Nanus, D. M., and Catterall, J. F. (1996). Androgen receptor CAG repeat lengths in prostate cancer: correlation with age of onset. *J. Clin. Endocrinol. Metab.* **81**:4400–4405.
- Hauck, J., and Dewey, D. (2001). Hand preference and motor functioning in children with autism. *J. Autism Dev. Disord.* **31**:265–277.
- Hepper, P., McCartney, G., and Shannon, E. (1998). Lateralised behaviour in first trimester human fetuses. *Neuropsychologia* **36**:521–534.
- Hepper, P., Shahidullah, S., and White, R. (1990). Handedness in the human foetus. *Neuropsychologia* **29**:1107–1111.
- Hickey, T., Chandy, A., and Norman, R. J. (2002). The androgen receptor CAG repeat polymorphism and X-chromosome inactivation in Australian Caucasian women with infertility related to polycystic ovary syndrome. *J. Clin. Endocrinol. Metab.* **87**:161–165.
- Irvine, R. A., Yu, M. C., Ross, R. K., and Coetzee, G. A. (1995). The CAG and GGC microsatellites of the androgen receptor gene are in linkage disequilibrium in men with prostate cancer. *Cancer Res.* **55**:1937–1940.
- Klar, A. J. S. (1999). Genetic models for handedness, brain lateralization, schizophrenia, and manic-depression. *Schizophrenia Res.* **39**:207–218.
- Kramer, M. A., Albrecht, S., and Miller, R. A. (1985a). Handedness and the laterality of breast cancer in women. *Nurs. Res.* **34**:333–337.
- Kramer, M. A., Albrecht, S., and Miller, R. A. (1985). Higher frequency of left-breast cancer: a possible explanation. *Percept Mot Skills* **61**:583–588.
- Krithivas, K., Yurgalevityh, S. M., Mohr, B. A., Wilcox, C. J., Batter, S. J., Brown, M., Longcope, C., McKinlay, J. B., and Kantoff, P. W. (1999). Evidence that the CAG repeat in the androgen receptor gene is associated with the age related decline in serum androgen levels in men. *J. Endocrinol.* **162**:137–142.
- La Spada, A. R., Wilson, E. M., Lubahn, D. B., Harding, A. E., and Fischbeck, K. H. (1991). Androgen receptor gene mutations in X-linked spinal and bulbar muscular atrophy. *Nature* **352**:77–79.
- Laval, S., Dann, J., Butler, R., Loftus, J., Rue, J., Leask, S., Bass, N., Comazzi, M., Vita, A., Nanko, S., Shaw, S., Peterson, P., Shields, G., Smith, A., Stewart, J., DeLisi, L., and Crow, T. (1998). Evidence for linkage to psychosis and cerebral asymmetry (relative hand skill) on the X chromosome. *Am. J. Med. Genet.* **7**:420–427.
- Lillie, E. O., Bernstein, L., and Ursin, G. (2003). The role of androgens and polymorphisms in the androgen receptor in the epidemiology of breast cancer. *Breast Cancer Res.* **5**:164–173.
- London, W. P. (1992). Reversed cerebral asymmetry and breast cancer. *Lancet* **339**:1055–1056.
- London, W. P., and Albrecht, S. A. (1991). Breast cancer and cerebral laterality. *Percept Mot Skills* **72**:112–114.
- McAbee, M. D., and DonCarlos, L. L. (1999). Estrogen, but not androgens, regulates androgen receptor messenger ribonucleic acid expression in the developing male rat forebrain. *Endocrinology* **140**:3674–3681.
- McManus, C. (2002). *Right Hand, Left Hand: The origins of asymmetry in Brains, Bodies, Atoms and Cultures*. London: Weidenfeld & Nicolson.
- McManus, I. C. (1985). Handedness, language dominance and aphasia: A genetic model. *Psychol. Med. Monographs Supplement* **8**:1–140.
- McManus, I. C. (1992). Reversed cerebral asymmetry and breast cancer. *Lancet* **339**:1055.
- Medland, S. E., Wright, M. J., Geffen, G. M., Hay, D. A., Levy, F., Martin, N., and Duffy, D. (2003). Special twin environments and their effects on the handedness of twins and their siblings. *Twin Res.* **6**:119–130.
- Moffat, S. D., and Hampson, E. (1996). Salivary testosterone levels in left- and right-handed adults. *Neuropsychologia* **34**:225–233.
- Natsopoulos, D., Koutselini, M., Kiosseoglou, G., and Koundouris, F. (2002). Differences in language performance in variations of lateralization. *Brain Lang.* **82**:223–240.
- Neale, M. C., Boker, S. M., Xie, G., and Maes, H. H. (2002). *Mx: Statistical Modeling* (6th Edition ed.). VCU Box 900126, Richmond, VA 23298 <http://www.vcu.edu/mx/>: Department of Psychiatry
- Newman, H. H. (1928). Studies of Human Twins II. Asymmetry reversal of mirrorimaging in identical twins. *Biol. Bull.* **55**:298–315.
- Piccioni, F., Pinton, P., Simeoni, S., Pozzi, P., Fascio, U., Vismara, G., Martini, L., Rizzuto, R., and Poletti, A. (2002). Androgen receptor with elongated polyglutamine tract forms aggregates that alter axonal trafficking and mitochondrial distribution in motor neuronal processes. *FASEB J.* **16**:1418–1420.
- Pujol, J., Deus, J., Losilla, J. M., and Capdevila, A. (1999). Cerebral lateralization of language in normal left handed people studies by functional MRI. *Neurology* **52**:1038–1043.

- Sandson, T. A., Wen, P. Y., and LeMay, M. (1992). Reversed cerebral asymmetry in women with breast cancer. *Lancet* **339**:523–524.
- Satz, P., and Green, M. F. (1999). Atypical handedness in schizophrenia: some methodological and theoretical issues. *Schizophrenia Bull.* **25**:63–78.
- Satz, P., Orsini, D. L., Saslow, E., and Henry, R. (1985). The pathological left-handedness syndrome. *Brain Cognition* **4**:27–46.
- Shaw, J., Claridge, G., and Clark, K. (2001). Schizotypy and the shift from dextrality: a study of handedness in a large non-clinical sample. *Schizophrenia Res.* **50**:181–189.
- Spurdle, A. B., Webb, P. M., Chen, X., Martin, N. G., Giles, G. G., Hopper, J. L., and Chenevix-Trench, G. (2000). Androgen receptor exon 1 CAG repeat length and risk of ovarian cancer. *Int. J. Cancer* **87**:637–643.
- Tan, U. (1990a). Relation of testosterone and hand preference in right-handed young adults to sex and familial sinistrality. *Int. J. Neurosci.* **53**:157–165.
- Tan, U. (1990b). Relationship of testosterone and nonverbal intelligence to hand preference and hand skill in right-handed young adults. *Int. J. Neurosci.* **54**:267–276.
- Titus-Ernstoff, L., Newcomb, P. A., Egan, K. M., Baron, J. A., Greenberg, E. R., Trichopoulos, D., Willett, W. C., and Stampfer, M. J. (2000). Left-handedness in relation to breast cancer risk in postmenopausal women. *Epidemiology* **11**:181–184.
- Tut, T., Ghadessy, F., Trifiro, M., Pinsky, L., and Yong, E. (1997). Long polyglutamine tracts in the androgen receptor are associated with reduced trans-activation, impaired sperm production, and male infertility. *J. Clin. Endocrinol. Metab.* **82**:3777–3782.
- Westberg, L., Baghael, F., Rosmond, R., Hellstrand, M., Landén, M., Jansson, M., Holm, G., Björntorp, P., and Eriksson, E. (2001). Polymorphisms of the androgen receptor gene and estrogen receptor beta gene are associated with androgen levels in women. *J. Clin. Endocrinol. Metab.* **86**:2562–2568.
- Witelson, S. F., and Nowakowski, R. S. (1991). Left out axons make men right: A hypothesis for the origin of handedness and functional asymmetry. *Neuropsychologia* **29**:327–333.
- Wright, M., De Geus, E., Ando, J., Luciano, M., Posthuma, D., Ono, Y., Hansell, N., Van Baal, C., Hiraishi, K., Toshikazu, H., Smith, G., Geffen, G., Geffen, L., Kanba, S., Miyake, A., Martin, N., and Boomsma, D. (2001). Genetics of Cognition: Outline of a Collaborative Twin Study. *Twin Res.* **4**:48–56.
- Yeap, B. B., Wilce, J. A., and Leedman, P. J. (2004). The androgen receptor mRNA. *Bioessays* **26**:672–682.
- Zhu, G., Duffy, D. L., Eldridge, A., Grace, M., Mayne, C., O’Gorman, L., Aitken, J. F., Neale, M. C., Hayward, N. K., Green, A. C., and Martin, N. G. (1999). A major quantitative-trait locus for mole density is linked to the familial melanoma gene CDKN2A: a maximum-likelihood combined linkage and association analysis in twins and their sibs. *Am. J. Human Genet.* **65**:483–492.
- Zhu, G., Evans, D. M., Duffy, D. L., Montgomery, G. W., Medland, S. E., Gillespie, N. A., Ewen, K. R., Jewell, M., Liew, Y. W., Hayward, N. K., Sturm, R. A., Trent, J. M., and Martin, N. G. (2004). A genome scan for eye colour in 502 twin families: most variation is due to a QTL on chromosome 15q. *Twin Res.* **7**:197–210.

Edited by Peter McGuffin